

Zero Power Consumption Sensor WG214



AHINJ
Nanjing AH

◆ 特点

Features

- No need the power supply when it works.
- Bipolar excitation working mode, the sensor outputs a pair of positive and negative electrical pulse signal when the magnetic field polarity changes for a circle.
- Only when the external magnetic field polarity changes, and magnetic strength reaches the excitation threshold, the sensor will outputs a pulse signal, so the vibration won't happen. The operation is stable and reliable.
- The signal amplitude has nothing to do with the magnetic field changing speed, and it can work at the speed near to zero.
- The output signal can be remote transmitted by the signal lines, so it's suitable for LAN management.
- No mechanic contact, no spark, is a kind of intrinsic safety devices.
- Wide operating temperature range, strong environmental adaptability.

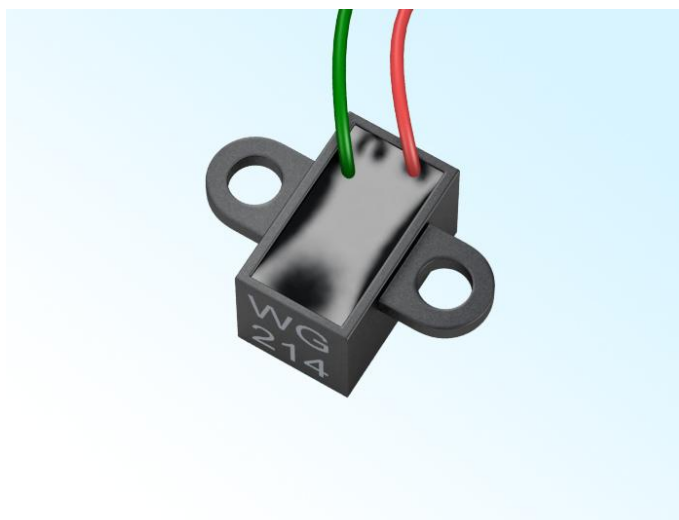

◆ Principle outline

Zero power consumption sensor WG112 (it also be called Wiegand Sensor) is a kind of new type magnetic component that is made based on Wiegand effect. It can initiative generate energy, no need external power when it works. It can give a sharp voltage pulse signal. The sensor consists of a special processed alloy wire and induction coil which winds on the outside of wire , framework and pins etc.

The alloy wire owns double magnetic structure, its core is soft magnet, and the shell is hard magnet. To utilize the magnetic difference between the alloy wire's inside and outside, under excitation by suitable strength of alternating magnetic field, the core magnetization direction everted in a moment, the direction became same or opposite with that of shell, and make the magnetic field around alloy wire changed suddenly, then a group of positive and negative pulse generated in the induction coil. The pulse amplitude is only regard with strength of the excitation field, and it has nothing to do with the field changing speed. It realized “Zero Speed” counting detection.

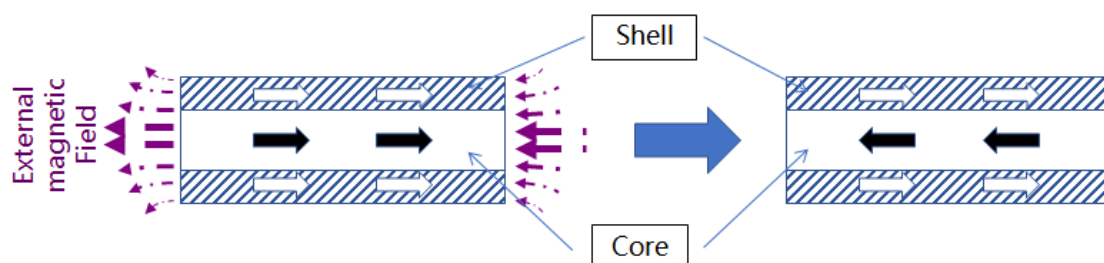

◆Product Parameter

Parameter	Symbol	Min.	Typ.	Max.	Unit
Excitation magnetic field	B	3	6	12	mT
Pulse signal amplitude	V_0	1.5			V
Pulse width	τ	10		30	us
DC resistor	R	650		1000	Ω
Operating frequency	f	—		10	kHz
Operating Temp.	B	-20		125	$^{\circ}\text{C}$

◆ Typical Circuit

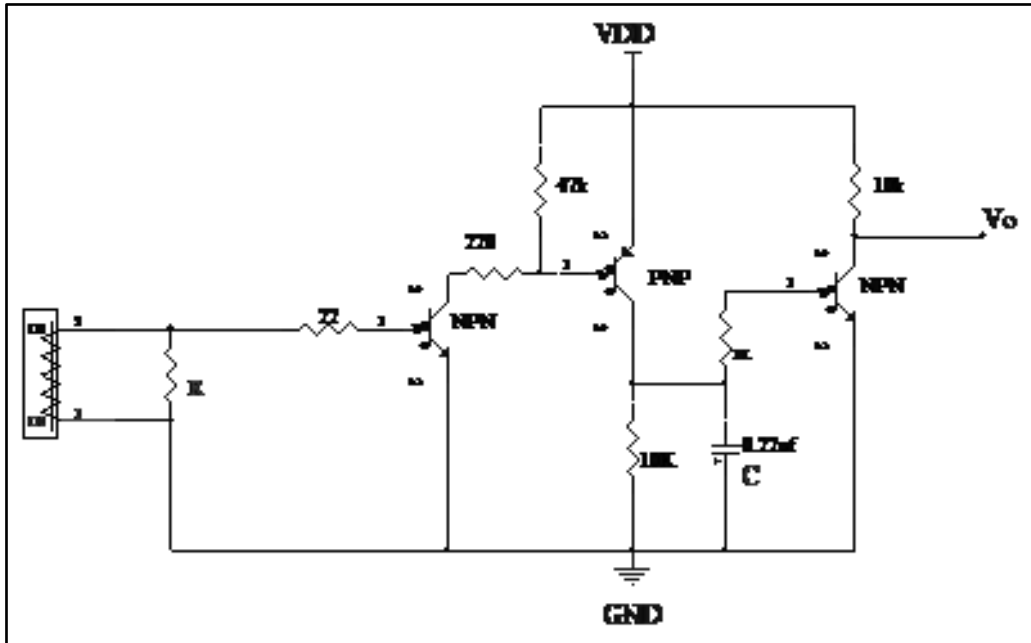

◆ Product Outline

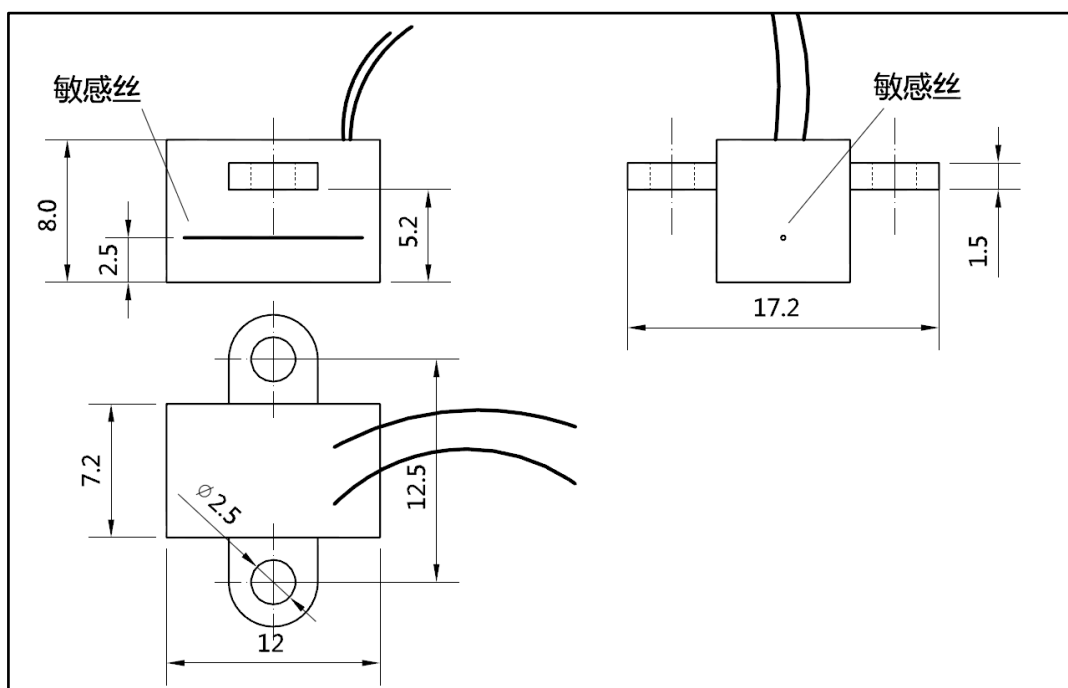

The Pins are soft wire, there is no distinguishing of positive and negative polarity

● Mark

The product mark is printed by ink, the parts No. is WG214.