

## 1 Features and Benefits

- ▲ Operating voltage range: 3.5 ~ 10.5V
- ▲ Rail to Rail voltage output
- ▲ Rated output current: 6 mA
- ▲ Stable switching signal without mechanical contact and spark
- ▲ High reliability and safety without shaking moment
- ▲ TO-92UA and SOT23-3L package options
- ▲ Developed according to the EU RoHS and REACH

## 2 Application Examples

- ▲ Automotive electronics, Consumer electronics and Industrial electronics
- ▲ Brake light wake-up switch
- ▲ Electronic steering column lock
- ▲ Door latch system
- ▲ BLDC Encoder
- ▲ Sunroof/Tailgate opener
- ▲ Transmission applications
- ▲ Electrical power steering

## 3 Selection Guide

Part Number	Packing	Mounting	Operating, T	S(Min)	S(Max)
AH3517/E-UA	Bulk, 1000 pieces/bag	3-pin SIP through hole	-40°C to 85°C	29mV/mT	33mV/mT
AH3517/E-M	7-in. reel, 3000 pieces/reel	3-pin SOT23-3L surface mount	-40°C to 85°C	29mV/mT	33mV/mT
AH3517/K-UA	Bulk, 1000 pieces/bag	3-pin SIP through hole	-40°C to 125°C	29mV/mT	33mV/mT
AH3517/K-M	7-in. reel, 3000 pieces/reel	3-pin SOT23-3L surface mount	-40°C to 125°C	29mV/mT	33mV/mT

NOTE 1. Hall ICs are soldered tin brazing for assembly, and wave soldering of SOT-23-3L surface-mounted components poses a risk of failure.  
 2. A risk of circuit failure may happen in non-brazing processes such as electric resistance welding, high-frequency welding, etc.  
 3. E: -40~85°C; K: -40~125°C; L: -40~150°C.

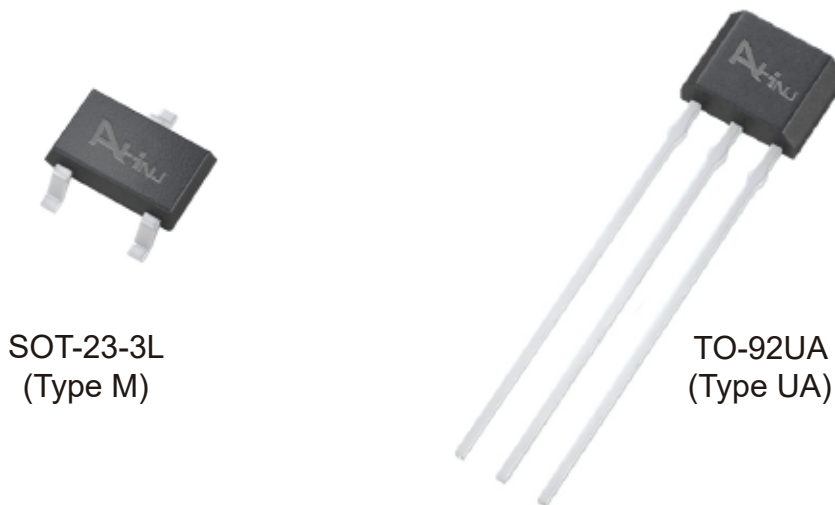

SOT-23-3L  
(Type M)

TO-92UA  
(Type UA)

## 4 General Description

The AH3517 is an analog signal output Hall IC, the output voltage changes with the changes of magnetic field. It has built-in circuit units such as reverse voltage protector, voltage regulator, temperature compensation circuit, Hall voltage generator, signal amplifier, etc. The high performance voltage regulator and temperature compensation circuit ensure that the sensor operates steadily over a wide range of voltages, and the reverse voltage protection circuit prevents the sensor from being damaged by the reverse voltage.

The AH3517 is produced with BCD technology. It is available in two package types: SOT-23-3L (Type M) and TO-92UA (Type UA). Each package is lead (Pb) free, with 100% matte tin plated leadframes.

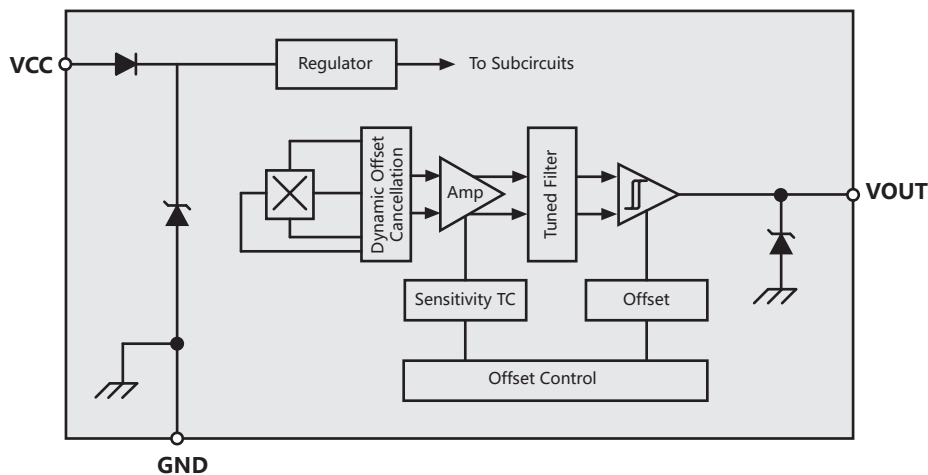

## 5 Terminal List

SOT-23-3L  
(Type M)

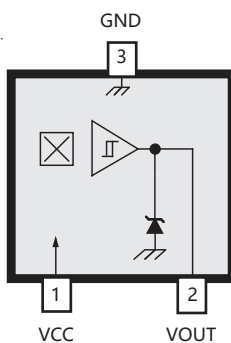

TO-92UA  
(Type UA)

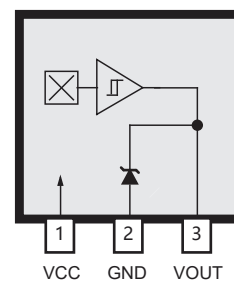

Name	Description	Number	
		Package M	Package UA
VCC	Connects power supply to chip	1	1
GND	Ground	2	2
VOUT	Output	3	3

## 6 Absolute Maximum Ratings

Characteristic	Symbol	Note	Rating	Unit
Supply Voltage	$V_{CC}$		11	V
Reverse Supply Voltage	$V_{RCC}$		-0.5	V
Maximum Output Voltage	$V_{OUTmax}$	test at 11V Supply Voltage	10.95	V
Minimum Output Voltage	$V_{OUTmin}$	test at 11V Supply Voltage	0.02	V
Output Current	$I_{OUTSINK}$		1	mA
Magnetic Flux Density	B		Unlimited	G
Operating Temperature	$T_A$	E	-40 to 85	°C
Operating Temperature	$T_A$	K	-40 to 125	°C
Maximum Junction Temperature	$T_{J(max)}$	Too high a $T_J$ could lead to electrical or thermal breakdown	165	°C
Storage Temperature	$T_{stg}$		-50 to 160	°C
ESD sensitivity – HBM	-		6	kV

NOTE 1. Human Body Model according to AEC-Q100-002 standard.

## 7 Electrical Operating Characteristics

valid through the full operating temperature range; unless otherwise specified

Characteristic	Symbol	Test Conditions	Min.	Typ.	Max.	Unit
Supply Voltage	$V_{CC}$	Operating, $T_J < 165^\circ\text{C}$	3.5	-	10.5	V
Null Voltage	$V_{OH}$	$V_{CC}=5\text{V}$ , no load on $V_{OUT}$	2.4	-	2.6	V
Output Voltage	$V_{OL}$	$V_{CC}=5\text{V}$ , $I_{OUTMAX}=1.0\text{mA}$	0.1	-	4.9	V
Supply Current	$I_{CC}$	$V_{CC}=5\text{V}$	-	5.5	8	mA

## 8 Magnetic Operating Characteristics

valid through the full operating temperature range; unless otherwise specified

Characteristic	Symbol	Test Conditions	Min.	Typ.	Max.	Unit
Sensitivity	S	$V_{CC}=5\text{V}$ , $T_A=25^\circ\text{C}$	29	31.25	33	mV/mT
Sensitivity Drift	$T_C$	Compare with the sensitivity under $25^\circ\text{C}$ within operating Temp.	0.06	0.12	0.18	°C/%
Sensitivity Tolerance	$\Delta S$	—	-10	-	+10	%
Delta $V_{NULL}$ as Temperature	$V_{NULL}(T)$	—	-1.5	-	+1.5	°C/%
Ratiometry $V_{NULL}$	$V_{NULL}(V)$	—	-5	-	+5	%
Linearity	L	—	-2.5	-	+2.5	%
Linear Area	LIN	—	-76	-	+76	mT

## 9 Magnetic Behavior

### Vo raises with increasing B (S pole)

The sensor will pass linear area /nonlinear area/ saturation area during the magnetic induction increases. When there is no magnetic field that applies in sensor ( $B=0$ ), the output voltage of sensor is only half of  $V_{cc}$  ( $V_{cc}/2$ ); when N pole faces mark surface of the sensor and is close to it gradually ( $B \rightarrow -\infty$ ), the output voltage begins to decrease, and the voltage doesn't reduce with the increased magnetic field after it reaches saturation voltage; When the S pole of magnet faces the mark surface of the sensor and is closed to it gradually ( $B \rightarrow +\infty$ ), the output voltage of sensor begins to increase, and it doesn't increase with the increased magnetic field after it reaches saturation voltage. The magnetolectric conversion characteristics of AH3517 are shown in the figure:

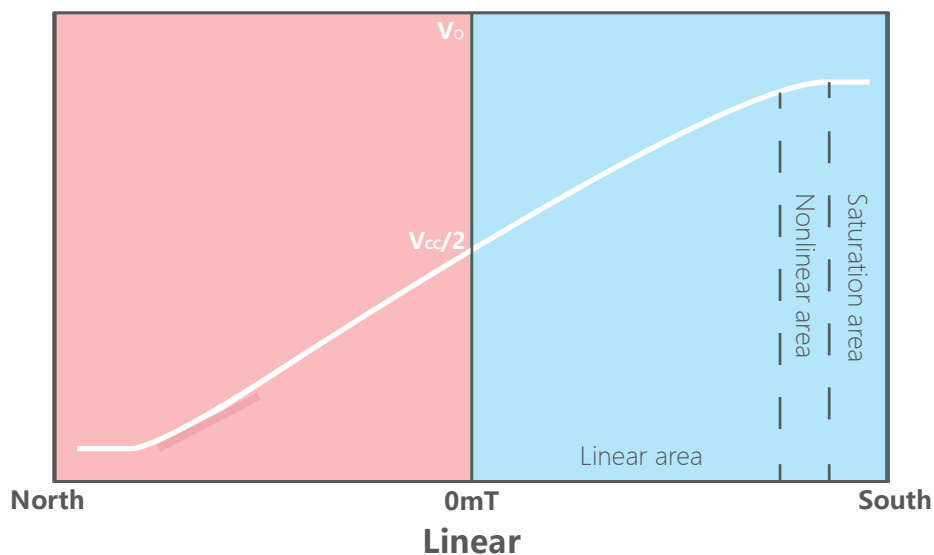

### Vo raises with increasing B (N pole)

The sensor will pass linear area /nonlinear area/ saturation area during the magnetic induction increases. When there is no magnetic field that applies in sensor ( $B=0$ ), the output voltage of sensor is only half of  $V_{cc}$  ( $V_{cc}/2$ ); when S pole faces mark surface of the sensor and is close to it gradually ( $B \rightarrow -\infty$ ), the output voltage begins to decrease, and the voltage doesn't reduce with the increased magnetic field after it reaches saturation voltage; When the N pole of magnet faces the mark surface of the sensor and is closed to it gradually ( $B \rightarrow +\infty$ ), the output voltage of sensor begins to increase, and it doesn't increase with the increased magnetic field after it reaches saturation voltage. The magnetoelectric conversion characteristics of AH3517 are shown in the figure:

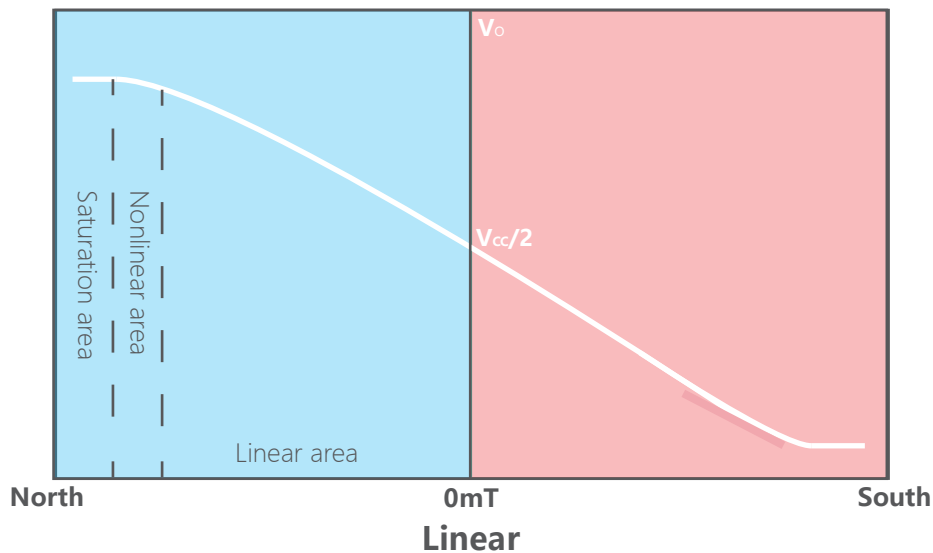

SOT-23-3L  
(Type M)

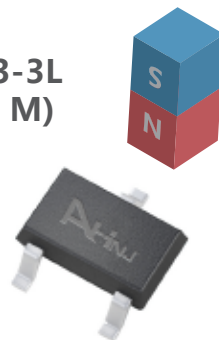

## 10 Package Information

### SOT-23-3L

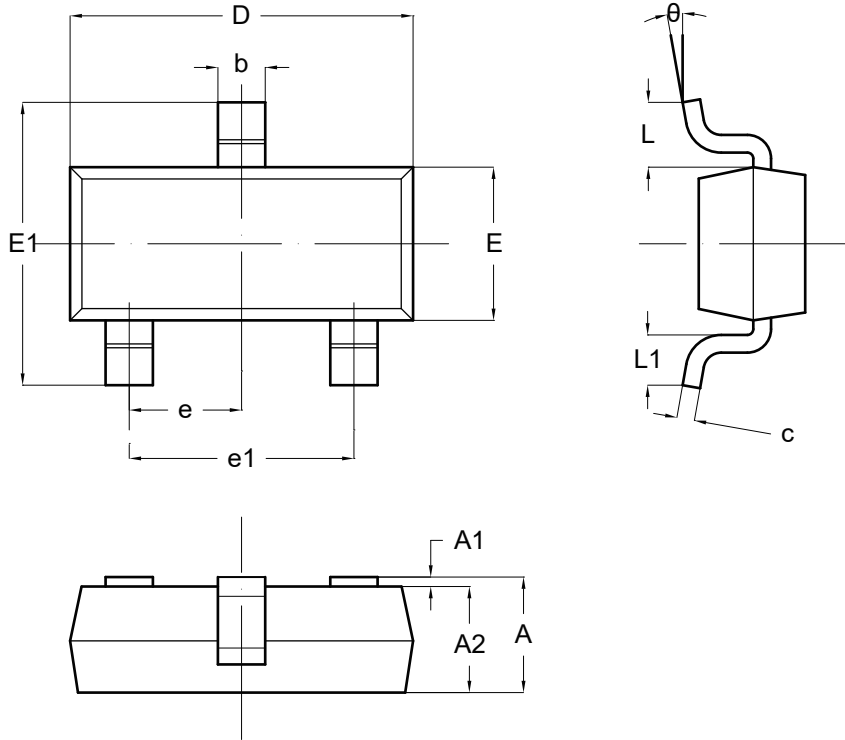

Symbol	Dimension (Unit: mm)	
	Min	Max
A	1.050	1.250
A1	0.000	0.100
A2	1.050	1.150
b	0.300	0.500
c	0.100	0.200
D	2.820	3.020
E	1.500	1.700
E1	2.650	2.950
e	0.950BSC.	
e1	1.800	2.000
L	0.550REF.	
L1	0.300	0.600
$\theta$	0°	8°

## TO-92UA

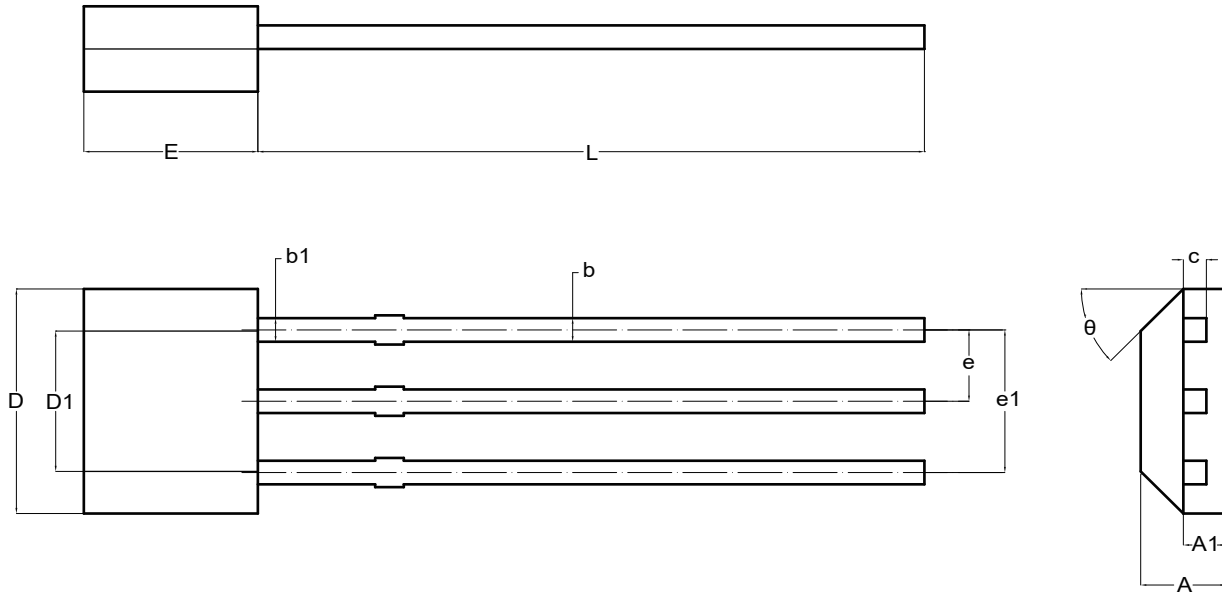

Symbol	Dimension (Unit: mm)	
	Min	Max
A	1.420	1.620
A1	0.660	0.860
b	0.330	0.480
b1	0.400	0.510
c	0.330	0.510
D	3.900	4.100
D1	2.280	2.680
E	3.050	3.250
e	1.270TYP.	
e1	2.440	2.640
L	14.350	14.750
$\theta$	45°TYP.	

## 12 Marking Information

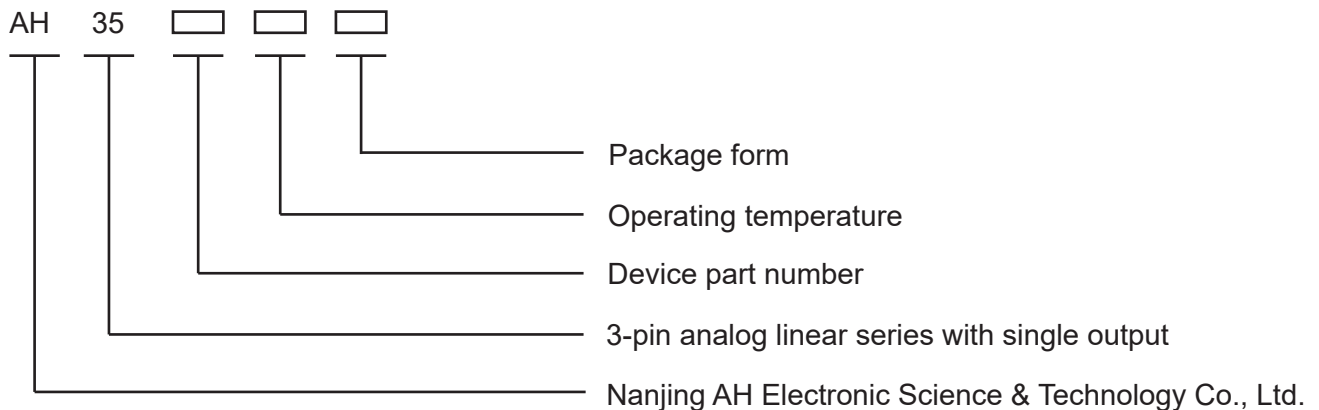

- Package Form:

M — SOT-23-3L (SMD)

S — SOT-89 (SMD)

UA — TO-92UA/TO-92S (SIP)

Note: M and S type are packed in reels, M 3k/reel, S 1k/reel;

UA type is packed in bags of 1k/bag or 0.5k/bag.

- Operating Temperature:

E —  $-40^{\circ}\text{C} \sim +85^{\circ}\text{C}$

L —  $-40^{\circ}\text{C} \sim +150^{\circ}\text{C}$

Copyright 2003~2020 Nanjing AH Electronic Science & Technology Co., Ltd.  
Nanjing AH Electronic Science & Technology Co., reserves the right to improve the performance, reliability or manufacturability of its products at any time according to detailed specifications. Before placing an order, the user is cautioned to verify that the information being relied upon is up-to-date. AHNJ's products are not to be used in any life support devices or systems (including but not limited to the listed devices or systems), in which a failure can reasonably be expected to cause bodily harm. The information included herein is believed to be accurate and reliable. However, Nanjing AH Electronic Science & Technology Co., assumes no responsibility for its use; nor for any infringement of patents or other rights of third parties which may result from its use.  
Learn more about our products for your application, please contact us:

[nianrong@ahest.com](mailto:nianrong@ahest.com)